

NOTES:

1. CAP ALL ENDS WITH PLASTIC CLOSURE CAPS / PLUGS.
2. ONLY HOSE AND FITTINGS THAT MEET MANUFACTURERS SPECIFICATIONS SHALL BE USED TO MAKE THESE HOSE ASSEMBLIES.
3. THIS STANDARD PART COVERS PERMANENT (CRIMP) END FITTINGS ONLY.
4. SPECIFY FITTINGS IN ALPHA - NUMERIC ORDER TO PREVENT DUPLICATE PART NUMBERS. (I.E. CSXX01X05X-XXXX, NOT CSXX05X01X-XXXX)

(SEE SHEET 2 OF 3 FOR MORE NOTES)

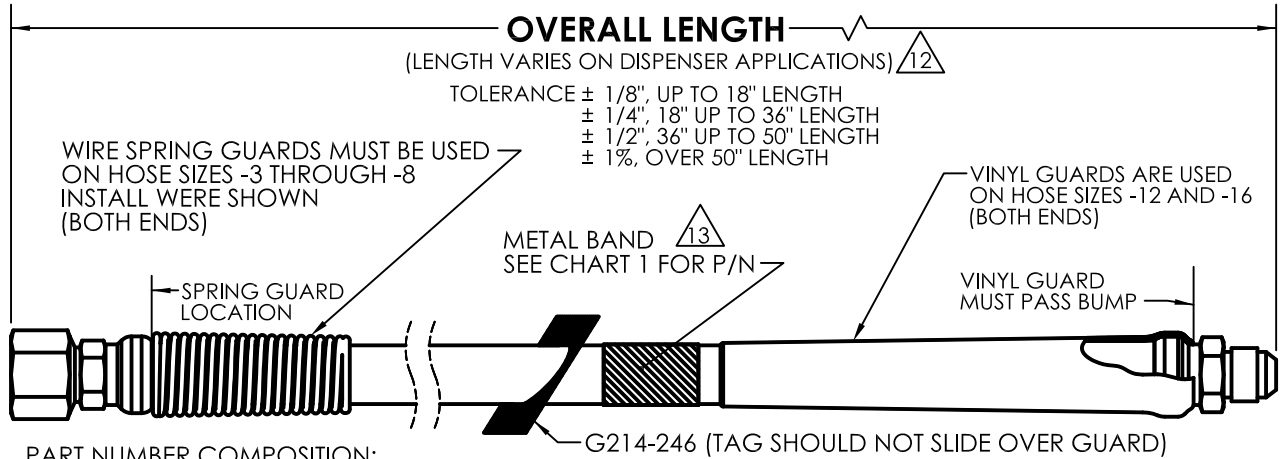

PART NUMBER COMPOSITION:

HCV X X XX X XX X - XXX X

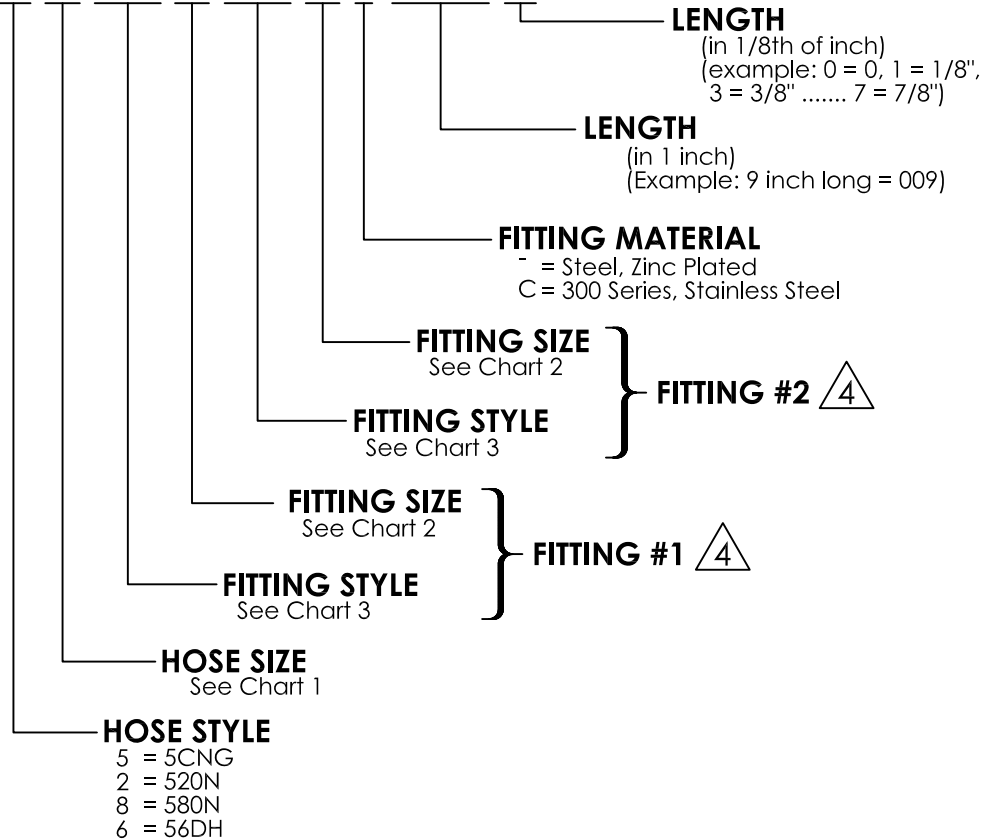

DELAFIELD STANDARD PART DRAWING

APPROVALS:		DATE:		Description:	HOSE ASSY, CNG, VENT LINE
DRAWN:	O. Mendoza 06/03/10			Part Number:	HCV-SERIES
CHECKED:				Sheet: 1 of 3	REVISION: -
APPROVED:					

NOTES:

- 5. ALL ASSEMBLIES ARE CERTIFIED AND TESTED IN COMPLIANCE WITH ANSI/IAS NGV 4.2/CSA 12.52-M99
- 6. ASSEMBLIES MUST BE COMPLETE (FITTINGS ON ALL ENDS OF HOSE).
- 7. ASSEMBLIES MUST BE PRESSURE / PROOF TESTED AND ELECTRICALLY TESTED FOR CONDUCTIVITY PER NFPA 52 AND PARFLEX QCI 2.8 AND QCI 2.12.
- 8. ANY HOSE ASSEMBLY NOT LISTED IN THIS DRAWINGS OR IN PARKER SPEC PFS-ES17 HAS NOT BEEN APPROVED FOR USE IN A CNG APPLICATION.
- 9. NPT END FITTINGS SHOULD NOT BE USED ON VEHICLE HOSES.
- 10. THIS HOSE IS NOT INTEND TO BE USED IN VEHICLE ENGINE APPLICATIONS.
- 11. HOSE COLOR TO BE RED.

12. HOSE ASSY FOR DISPENSER APPLICATIONS HAVE A MAX. ALLOWABLE LENGTH OF 16 FT - 4 IN.

13. INFO ON BAND: DELAFIELD
 ASSEMBLY P/N
 ASSEMBLY FOR CNG
 DATE (XX/XX/XX)
 CSA
 ANSI/IAS NGV 4.2 CSA 12.52





CAHRT 1						
HOSE SIZE						
DASH NO.	HOSE SIZE	CRIMP FITTING <u>5CNG-SERIES</u>	GUARD	CRIMP FITTING <u>520N-SERIES</u>	GUARD	METAL BAND
A	-4	58 SERIES	5PS G-4	55 SERIES	3PSG-4	714-000
B	-6	55 SERIES	5PS G-6			714-000
C	-8	58 SERIES	5PS G-8			714-000
E	-12	58 SERIES	CNGG5-16	-	-	M714-000
F	-16	58H SERIES	CNGG5-16	-	-	M714-000
H	-2	-	-	-	-	714-000
DASH NO.	HOSE SIZE	CRIMP FITTING <u>580N-SERIES</u>	GUARD	CRIMP FITTING <u>56DH-SERIES</u>	GUARD	METAL BAND
A	-4	58 SERIES	5PSG-4	-	-	714-000
B	-6	-	-	-	-	714-000
C	-8	-	-	-	-	714-000
E	-12	-	-	-	-	M714-000
F	-16	-	-	-	-	M714-000
H	-2	-	-	CY SERIES	CY02-652317	714-000

CAHRT 2	
FITTING SIZE	
DASH NO.	DASH NO.
A	-4
B	-6
C	-8
D	-10
E	-12
F	-16
H	-2

DELAFIELD STANDARD PART DRAWING

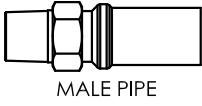
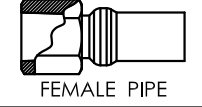
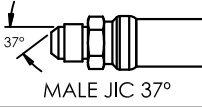
APPROVALS:	DATE:		Description:	HOSE ASSY, CNG, VENT LINE
DRAWN:	O. Mendoza 06/03/10		Part Number:	HCV-SERIES
CHECKED:	SEE SHEET 1		Sheet: 2 of 3	REVISION: -
APPROVED:	SEE SHEET 1			

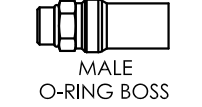
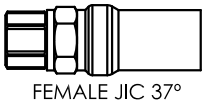
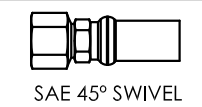
FITTING STYLE / AVAILABLE FITTING SIZE (55, 58 & CY SERIES)

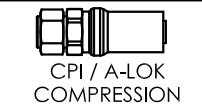
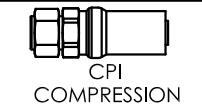
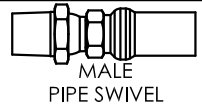
DASH NO.	FITTING STYLE HOSE TYPE	VENT LINE, HOSE AND FITTING CONFIGURATION																				
		520N-4		580N-4		5CNG-4		5CNG-6		5CNG-8		5CNG-12		5CNG-16		56DH-2						
01	 MALE PIPE	10155	10155	10158	10155	10158	10158H	10158H	101CY													
		-4	-4	-4	-6	-8	-12	-16	-2													
		-2	-4	-6	-2	-4	-6	-2	-4	-6	-4	-6*	-8*	-6	-8*	-	-	-	-12*	-12	-16*	-2
02	 FEMALE PIPE	10255	10255	10258	10255	10258																
		-4	-4	-4	-6	-8																
		-4	-6	-	-4	-6	-	-4	-6	-	-	-6	-8	-	-8	-	-					
03	 MALE JIC 37°	10355	10355	10358	10355	10358																
		-4	-4	-4	-6	-8																
		-4	-5	-6	-4	-5	-6	-4	-5	-6	-	-6	-8	-	-8	-10	-					
04	 MALE SAE 45°	10455	10455	10458	10455	10458																
		-4	-4	-4	-6	-8																
		-	-5	-	-	-5	-	-	-5	-	-	-6	-	-6	-8	-	-					
05	 MALE O-RING BOSS	10555	10555	10558	10555	10558																
		-4	-4	-4	-6	-8																
		-4	-5	-6	-4	-5	-6	-4	-5	-6*	-	-6*	-8	-	-8	-10	-					
06	 FEMALE JIC 37°	10655	10655	10658	10655	10658	10658H	10658H	106CY													
		-4	-4	-4	-6	-8	-12	-16	-2													
		-4	-5	-6	-4	-5	-6	-4	-5	-6	-	-6	-8	-6	-8	-10	-12	-8	-12	-	-16	-2
08	 SAE 45° SWIVEL	10855	10855	10858	10855								108CY									
		-4	-4	-4	-6								-2									
		-	-6	-	-	-6	-	-	-6	-	-	-6	-8			-	-	-4				
JC	 SEAL-LOK STRAIGHT SHORT	1JC55	1JC55	1JC58	1JC55	1JC58	1JC58H	1JC58H														
		-4	-4	-4	-6	-8	-12	-16														
		-4	-6	-	-4	-6	-	-4	-6	-	-	-6	-8	-	-8	-10	-	-	-12*	-	-16	
JS	 SEAL-LOK STRAIGHT	1JS55	1JS55	1JS58	1JS55	1JS58	1JS58H	1JS58H														
		-4	-4	-4	-6	-8	-12	-16														
		-4	-6	-	-4	-6	-	-4	-6	-	-	-6	-8	-	-8	-	-	-	-12	-	-16	
AL	 CPI / A-LOK COMPRESSION	1AL55	1AL55	1AL58	1AL55	1AL58																
		-4	-4	-4	-6	-8																
		-4	-	-	-4	-	-	-4	-	-	-	-6	-	-	-8	-	-					
P6	 CPI COMPRESSION	1P655	1P655	1P658	1P655	1P658																
		-4	-4	-4	-6	-8																
		-4	-	-	-4	-	-	-4	-	-	-	-6	-	-	-8*	-	-					
13	 MALE PIPE SWIVEL								113CY													
									-2													
									-2	-	-											

SAMPLE

* = STAINLESS STEEL AVAILABLE.

FITTING STYLE	08		10855	SERIES
		SAE 45° SWIVEL	-6	HOSE SIZE
			- - -8	FITTING THREAD

DELAFIELD STANDARD PART DRAWING

APPROVALS:	DATE:		Description:	HOSE ASSY, CNG, VENT LINE
DRAWN:	O. Mendoza 06/03/10		Part Number:	HCV-SERIES
CHECKED:	SEE SHEET 1		Sheet: 3 of 3	REVISION: -
APPROVED:	SEE SHEET 1			