

# Dual Lock



*The Right Connection™*

## Dual-Lock

# Quick Acting Couplings

*Dual-Lock couplings allow full air flow for general purpose air handling requiring high flow and pneumatic impact tools.*

### Service:

- The recommended working pressure for Dual-Lock quick acting couplings is **300 PSI**.
- The operating temperature range is **-40° to +250°F** (-40° to +121°C).

### Features:

- Unisex design
- Spring loaded interlocking engagement
- Corrosion resistant coating
- Smooth ID permits full flow paths to tool
- Optional locking key prevents accidental sleeve retraction

### Configurations:

- Hose barb
- Male pipe thread
- Female pipe thread
- Locking sleeve
- Knurled flange sleeve

### Materials:

- Body: trivalent chrome plated steel  
*optional* - brass or 303 stainless steel
- Sleeve: trivalent chrome plated steel  
*optional* - brass or 303 stainless steel
- Retaining ring and spring: phosphor bronze
- Seal: nitrile (buna-n)  
*optional* - Viton®

### Connecting:

- Push and Twist  
*Locking clip is available to prevent unintentional disconnection.*

### Disconnecting:

- Pull and Twist  
**Never attempt to disconnect any hose while pressure is in the line.**

SAFETY  
ALERT

### Interchange:

- Interchangeable with Thor and National brands

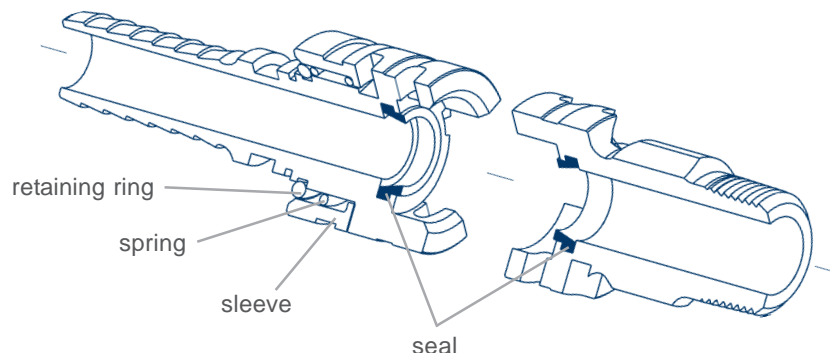

## HOSE COUPLING SAFETY

- Use Dixon couplings, retention devices and accessory products **only** for their intended service.
- All recommendations of the Hose Manufacturer, and the Coupling Manufacturer, must be employed with regards to **Size, Temperature, Application, Media, and Pressure** when selecting the components for a hose assembly.
- All finished hose assemblies should be tested in accordance with the Rubber Manufacturers Association recommendations.
- All hose assemblies should be thoroughly inspected prior to each use to ensure they are undamaged, and properly coupled.
- Use safety clips on couplings, and King Safety Cables on assemblies where required by the manufacturer, as well as State and Federal regulations. (OSHA regulations may be viewed in full on the OSHA website, [www.osha.gov](http://www.osha.gov).)
- Under no circumstances should the assembly working pressure or working temperature exceed the working pressure or working temperature of the lowest rated component (coupling, clamp, ferrule, or hose).
- Call Dixon (800.355.1991) for advice on couplings, retention devices, and accessories for your application.

Viton® is a registered trademark of DuPont Dow Elastomers.

SAFETY  
ALERT

### Hose Barb with Locking Sleeve

Body Size	Hose Size	Part #			pkg qty
		Plated Steel	Brass	Stainless Steel	
1/2"	3/8"	<b>PHL6</b>	----	----	25
1/2"	1/2"	<b>PHL8</b>	----	----	25
1/2"	3/4"	<b>PHL12</b>	<b>PHLB12</b>	<b>PHL12SS</b>	25
1/2"	1"	<b>PHL16</b>	<b>PHLB16</b>	----	25

Dimensions

Size	A	B
3/8"	3.53"	1.55"
1/2"	3.95"	1.55"
3/4"	3.95"	1.55"
1"	6.06"	1.55"

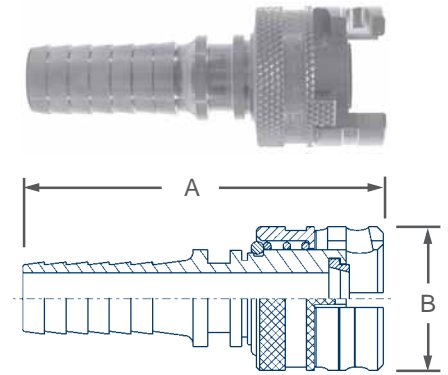

### Male Pipe Thread with Locking Sleeve

Body Size	Thread Size	Part #		pkg qty
		Plated Steel	Stainless Steel	
1/2"	3/8"	<b>PML6</b>	----	25
1/2"	1/2"	<b>PML8</b>	----	25
1/2"	3/4"	<b>PML12</b>	<b>PML12SS</b>	25

Dimensions

Size	A	B
1/2"	2.93"	1.55"
3/4"	3.11"	1.55"
1"	3.13"	1.55"

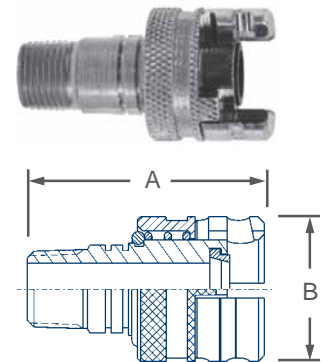

### Female Pipe Thread with Locking Sleeve

Body Size	Thread Size	Part #		pkg qty
		Plated Steel	Stainless Steel	
1/2"	1/2"	<b>PFL8</b>	----	25
1/2"	3/4"	<b>PFL12</b>	<b>PFL12SS</b>	25

Dimensions

Size	A	B	HEX
1/2"	1.55"	1.55"	1.38"
3/4"	1.55"	1.55"	1.38"

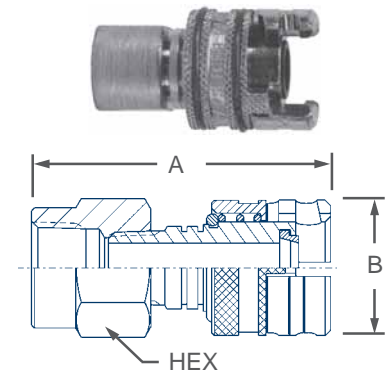

Must be used with locking sleeve fittings above.

Body Size	Thread Size	Part #			pkg qty
		Plated Steel	Brass	Stainless Steel	
1/2"	3/8"	<b>PM6</b>	----	----	25
1/2"	1/2"	<b>PM8</b>	<b>PMB8</b>	----	25
1/2"	3/4"	<b>PM12</b>	<b>PMB12</b>	<b>PM12SS</b>	25
1/2"	1"	<b>PM16</b>	<b>PMB16</b>	----	25

Dimensions

Size	A	B	FLAT
3/8"	2.00"	1.55"	0.88"
1/2"	2.25"	1.55"	0.97"
3/4"	2.55"	1.55"	1.13"
1"	3.25"	1.55"	1.38"

### Male Pipe Thread

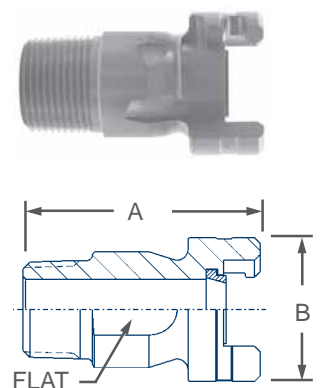

## Female Pipe Thread

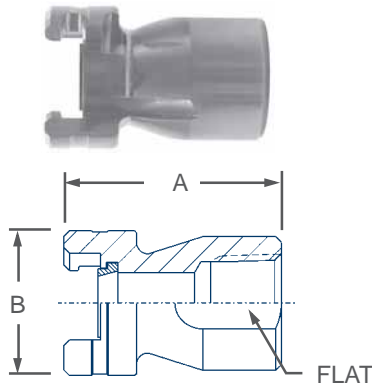

Must be used with locking sleeve fittings on page 3.

Body Size	Thread Size	Plated Steel	Part # Brass	Stainless Steel	pkg qty
		<b>PF6</b>	----	----	
1/2"	3/8"	<b>PF8</b>	<b>PFB8</b>	----	25
1/2"	1/2"	<b>PF12</b>	<b>PFB12</b>	<b>PF12SS</b>	25
1/2"	3/4"	<b>PF16</b>	<b>PFB16</b>	----	25

### Dimensions

Size	A	B	FLAT
3/8"	1.79"	1.55"	0.88"
1/2"	2.25"	1.55"	0.97"
3/4"	2.34"	1.55"	1.13"
1"	2.76"	1.55"	1.38"

## Hose Barb with Knurled Flanged Sleeve

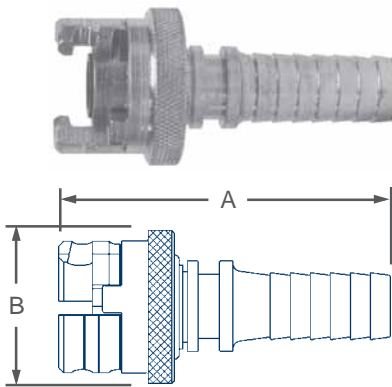

Large, raised collar sleeve permits easier handling when wearing gloves.

Body Size	Hose Size	Part # Plated Steel	pkg qty
		<b>PHL6FS</b>	
1/2"	3/8"	<b>PHL8FS</b>	25
1/2"	1/2"	<b>PHL12FS</b>	25

### Dimensions

Size	A	B
3/8"	3.53"	1.81"
1/2"	3.95"	1.81"
3/4"	3.95"	1.81"

## Male Pipe Thread with Knurled Flanged Sleeve

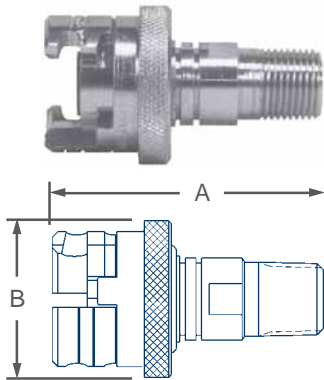

Large, raised collar sleeve permits easier handling when wearing gloves.

Body Size	Thread Size	Part # Plated Steel	pkg qty
		<b>PML6FS</b>	
1/2"	3/8"	<b>PML8FS</b>	25
1/2"	1/2"	<b>PML12FS</b>	25

### Dimensions

Size	A	B
3/8"	2.93"	1.81"
1/2"	3.11"	1.81"
3/4"	3.13"	1.81"

## Female Pipe Thread with Knurled Flanged Sleeve

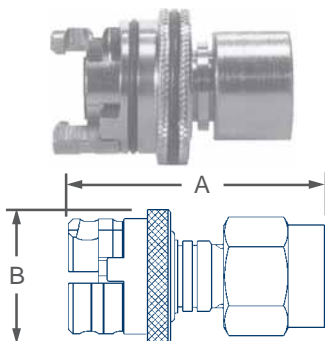

Large, raised collar sleeve permits easier handling when wearing gloves.

Body Size	Thread Size	Part # Plated Steel	pkg qty
		<b>PFL8FS</b>	
1/2"	1/2"	<b>PFL12FS</b>	25

### Dimensions

Size	A	B
1/2"	3.43"	1.81"
3/4"	3.43"	1.81"



## Crimped Recommendation Guide

The chart below is only a guide. It will not apply to every coupling situation. In some instances alternative dies and crimping dimensions must be employed to ensure safety. Experience has shown that variances in the construction of similar hoses and couplings may cause some assemblies to react differently when crimped. It is not uncommon to find hose with an outer diameter that fluctuates from one end to the other or from production lot to production lot. These inconsistencies coupled with the inherent differences between textile or wire braid, hard or soft wall, the presence or absence of an internal spiral wire and the differences in hose coverings make it difficult to establish hard and fast rules. Therefore, it is imperative that hose dimensions are accurately measured, assemblies are tested, and documentation is maintained.

Hose I.D.	Part #	Hose O.D.		Crimp Diameter (±0.005)	Crimp Length	% Reduction
		Fractional	Decimal			
½"	PHL8WF	54/64	0.844	0.925	1-1/4	18.9
		55/64	0.859	0.940	1-1/4	18.1
		56/64	0.875	0.950	1-1/4	18.9
		57/64	0.891	0.965	1-1/4	18.4
		58/64	0.906	0.975	1-1/4	19.0
		59/64	0.922	0.990	1-1/4	18.5
		60/64	0.938	1.005	1-1/4	18.0
		61/64	0.953	1.015	1-1/4	18.5
		62/64	0.969	1.030	1-1/4	18.1
		63/64	0.984	1.040	1-1/4	18.6
		1	1.000	1.055	1-1/4	18.2
		1-1/64	1.016	1.065	1-1/4	18.8
		1-2/64	1.031	1.080	1-1/4	18.3
¾"	PHL12WF	1-10/64	1.156	1.220	1-1/4	18.5
		1-11/64	1.171	1.235	1-1/4	18.0
		1-12/64	1.187	1.244	1-1/4	18.7
		1-13/64	1.203	1.260	1-1/4	18.1
		1-14/64	1.218	1.270	1-1/4	18.8
		1-15/64	1.234	1.285	1-1/4	18.2
		1-16/64	1.250	1.295	1-1/4	18.8
		1-17/64	1.265	1.310	1-1/4	18.4
		1-18/64	1.281	1.320	1-1/4	18.8
		1-19/64	1.296	1.335	1-1/4	18.5
		1-20/64	1.312	1.345	1-1/4	19.0
		1-21/64	1.328	1.360	1-1/4	18.5
		1-22/64	1.343	1.370	1-1/4	19.0









## Installation Guide

### Procedure 2306

- Prepare the hose.
- Select the proper fitting from the Holedall Die Chart or the current Dixon catalog (DPL).
- From the Holedall Die Chart, determine proper crimp diameter and crimp length.
- Depending upon type of crimper, set crimp diameter on machine or select die cage and spacers to achieve required crimp diameter.
- Measure the distance from the end of the ferrule to the stem collar. Place a mark (line) on the hose (from the hose end) corresponding with this distance.
- Insert the coupling into the hose until the end of the ferrule is even with the line just placed on the hose.
- Mark the crimp length on the ferrule.
- Insert the coupling through the crimper die segments until the line on the ferrule is at the end of the die segments. Jog the machine until the die segments lightly contact the ferrule. Adjust fitting, if necessary, to ensure line is at end of die segments.
- With light pressure on hose to ensure stem collar is contacting ferrule, activate the crimper until desired crimp diameter has been achieved.
- Reverse machine and remove the coupling from the die segments. Measure the crimp diameter with dial calipers or micrometer.
- Test assembly if required.

*A printed copy of the complete Installation and Inspection Procedures Manual is available upon request.*

## Dual Lock Interchange Guide

Size	Material	Dixon Part #	Dixon Quick Coupling Part #	National Part #	
					<b>Hose Barb with Locking sleeve</b>
3/8"	steel	<b>PHL6</b>	4PS3	HS6	
1/2"	steel	<b>PHL8</b>	4PS4	HS8	
3/4"	steel	<b>PHL12</b>	4PS6	HS12	
	brass	<b>PHLB12</b>	4PS6-B	HB12	
	stainless	<b>PHL12SS</b>	4PS6-S	---	
1"	steel	<b>PHL16</b>	4PS8	HS16	
	brass	<b>PHLB16</b>	4PS8-B	---	
					<b>Male Pipe Thread with Locking Sleeve</b>
3/8"	steel	<b>PML6</b>	4PM3	MLS6	
1/2"	steel	<b>PML8</b>	4PM4	MLS8	
3/4"	steel	<b>PML12</b>	4PM6	MLS12	
	stainless	<b>PML12SS</b>	4PM6-S	---	
					<b>Female Pipe Thread with Locking Sleeve</b>
1/2"	steel	<b>PFL8</b>	4PF4	FLS8	
3/4"	steel	<b>PFL12</b>	4PF6	FLS12	
	stainless	<b>PFL12SS</b>	4PF6-S	---	
					<b>Male Pipe Thread</b>
3/8"	steel	<b>PM6</b>	P4M3	MS6	
1/2"	steel	<b>PM8</b>	P4M4	MS8	
	brass	<b>PMB8</b>	P4M4-B	MB8	
3/4"	steel	<b>PM12</b>	P4M6	MS12	
	brass	<b>PMB12</b>	P4M6-B	MB12	
	stainless	<b>PM12SS</b>	P4M6-S	---	
1"	steel	<b>PM16</b>	P4M8	MS16	
	brass	<b>PMB16</b>	P4M8-B	---	
					<b>Female Pipe Thread</b>
3/8"	steel	<b>PF6</b>	P4F3	FS6	
1/2"	steel	<b>PF8</b>	P4F4	FS8	
	brass	<b>PFB8</b>	P4F4-B	FB8	
3/4"	steel	<b>PF12</b>	P4F6	FS12	
	brass	<b>PFB12</b>	P4F6-B	FB12	
	stainless	<b>PF12SS</b>	P4F6-S	---	
1"	steel	<b>PF16</b>	P4F8	FS16	
	brass	<b>PFB16</b>	P4F8-B	---	
					<b>Hose Barb with Knurled Flanged Sleeve</b>
3/8"	steel	<b>PHL6FS</b>	4PS3-FS	---	
1/2"	steel	<b>PHL8FS</b>	4PS4-FS	---	
3/4"	steel	<b>PHL12FS</b>	4PS6-FS	---	
					<b>Male Pipe Thread with Knurled Flanged Sleeve</b>
3/8"	steel	<b>PML6FS</b>	4PM3-FS	---	
1/2"	steel	<b>PML8FS</b>	4PM4-FS	---	
3/4"	steel	<b>PML12FS</b>	4PM6-FS	---	
					<b>Female Pipe Thread with Knurled Flanged Sleeve</b>
1/2"	steel	<b>PFL8FS</b>	4PF4-FS	---	
3/4"	steel	<b>PFL12FS</b>	4PF6-FS	---	

Through its divisions and affiliated companies, Dixon is recognized as the premier manufacturer and supplier of hose fittings and accessories spanning a wide range of industrial uses. Dixon's reach includes products for fire protection, food, dairy processing, beverage and brewery, mobile tankers, mining, construction, chemical processing, petroleum, oilfields, refining, nuclear and manufacturing.



*The Right Connection™*

**Dixon Valve & Coupling Company**

800 High Street, Chestertown, MD 21620

Customer Service: 877.963.4966

Fax: 800.283.4966

**[www.dixonvalve.com](http://www.dixonvalve.com)**